

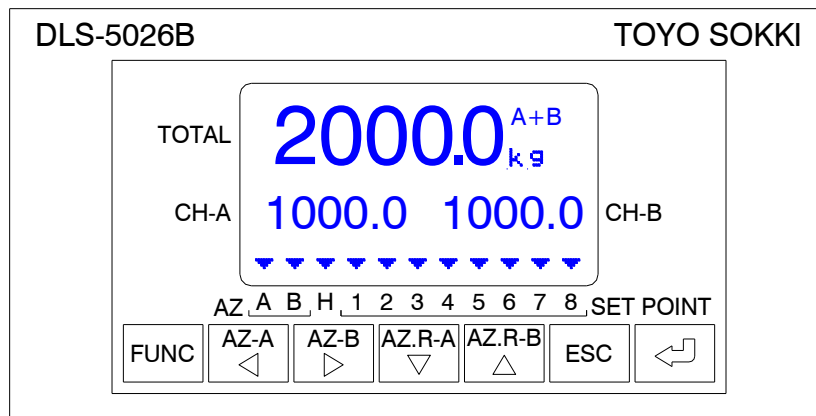

DIGITAL INDICATOR

MODEL DLS-5026B

OPERATION MANUAL



TOYO SOKKI CO.,LTD.

964-24 Nippa-cho Kohoku-ku, Yokohama 223-0057 Japan
TEL +81-45-540-8353
FAX +81-45-544-8354

§ 1. SUMMARY	3
§ 2. INSTALLATION AND CONNECTION METHOD OF THE UNIT	4
2 – 1) Installation environment of this unit	4
2 – 2) To obtain stable measurement	4
§ 3. APPEARANCE AND EACH PART NAME.....	5
§ 4. OPERATION.....	7
4 – 1) Measuring Mode.....	7
4 – 2) Function Mode.....	9
4 – 3) Test Mode	9
§ 5. CALIBRATION	10
5 – 1) Cancel Calibration Lock	10
5 – 2) Preparation 1, prior to calibration (FCAL SETTING).....	11
5 – 3) Preparation 2, prior to calibration (CH-A SETTING)	11
5 – 4) Preparation 3, prior to calibration (CH-B SETTING)	11
5 – 5) Calibration 1, by actual load calibration (CH-A CAL)	12
5 – 6) Calibration 2, by actual load calibration (CH-B CAL)	12
5 – 7) Calibration 1, by equivalent input calibration (CH-A CAL)	12
5 – 8) Calibration 2, by equivalent input calibration (CH-B CAL)	12
§ 6. OPTION (SPECIFIED AT THE TIME OF SHIPMENT).....	13
6 – 1) Analog Output (OP-1 / OP-2).....	13
6 – 2) RS-232C serial interface (OP-3)	15
§ 7. FUNCTION MODE.....	17
7 – 1) How to operate.....	17
7 – 2) Function Table	17
§ 8. TEST MODE	24
8 – 1) Operation method	24
8 – 2) Test item	24
§ 9. TROUBLESHOOTING.....	25
9 – 1) Basic check point	25
9 – 2) Precautions at the time of calibration.....	25
9 – 3) Countermeasure when abnormal display is indicated	25
9 – 4) Judgement whether this unit has malfunction	25
9 – 5) Checking Sensor (Load Cell)	26
§ 10. SPECIFICATIONS	27
10 – 1) A/D convert part	27
10 – 2) Display part	27
10 – 3) Zero point and sensitivity adjustment	27
10 – 4) I/O part.....	27
10 – 5) Option.....	28
10 – 6) General	28
§ 11. LIST OF MODELS AND ACCESSORIES	29
11 – 1) Model.....	29
11 – 2) Accessories	29
§ 12. TERMINAL LAYOUT.....	30
§ 13. DIMENSIONAL DRAWING.....	32
§ 14. FUNCTION BLOCK DIAGRAM	32

※This operation manual conforms to program version 2.00 and later.

This document is translated from MA4-00248-R2 (Japanese)

§ 1. Summary

This indicator has two signal input channels from the distortion gauge type transducer and performs sampling 100 times per second of incoming signals and two channels are synchronized.

Also this indicator has various functions such as comparator function, hold function, and zero tracking function, etc.

Other than the measurement of each channel of CH-A and CH-B, the measurement of addition / subtraction, as CH-A+CH-B or CH-A-CH-B, is carried out simultaneously.

This unit has 8 comparators which is able to output 8 comparison results through open collectors of transistors.

As an option, 3 analog output corresponding to the measured value of each channel CH-A, CH-B and calculated value TOTAL converted from digital data can be output.

The power supplied voltage is the wide range of voltage AC100 to 240V.

§ 2. Installation and connection method of the unit

2 – 1) Installation environment of this unit

- 1) Operation temperature range of this unit is 0°C to +40°C.
Please install this unit in a place not exposed to direct sunlight and condensation.
- 2) The power supply is AC100V to 240V.
Recommend to use a constant-voltage transformer if power supply is not stable.
- 3) This unit is designed to fix by a panel-mount. Please make use of the attached metal fittings to fix it on.
- 4) Please confirm the cable specification before wiring this unit.
- 5) A shield line of each cable should be ground to either one of this unit or each connected equipment.

2 – 2) To obtain stable measurement

When a sensor of strain gauge (i.e., Load Cell, Pressure gauge) is amplified by an amplifier or is connected to an indicator, the value may fluctuate or may not be stable.

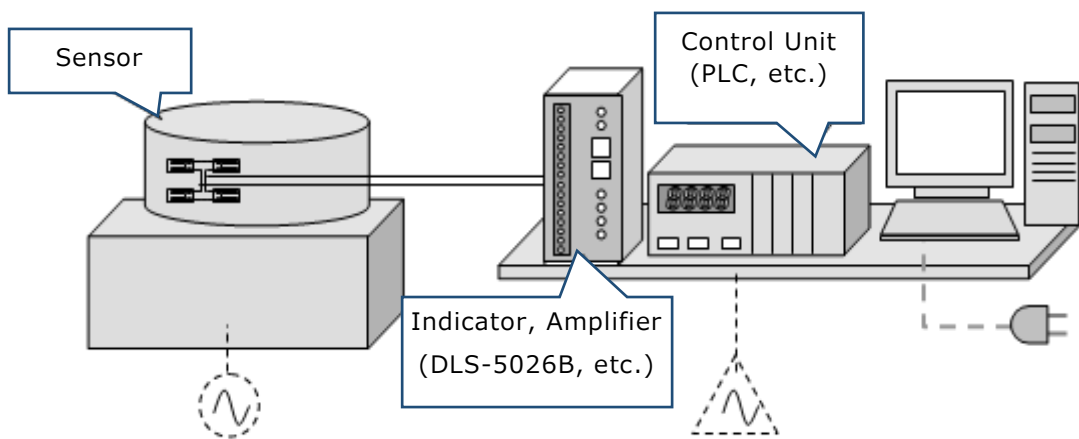

(Fig. 1)

This is because of difference of an electric potential between a sensor part and an amplifier / indicator part. It is induced from electric potential of commercial power (AC100V/AC200V).

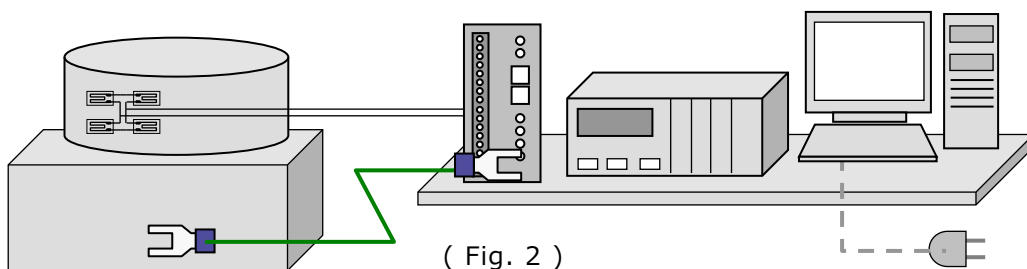

(Fig. 2)

The most effective way to improve stability is to use a cable to connect an Earth terminal of an amplifier / indicator to a case or chassis of sensor, like Fig 2.

If it is difficult to find an Earth terminal of sensor side, loose a bolt of metal case of sensor and connect the cable. Please make the electric potential be same as possible.

In case that a sensor and amplifier / indicator have installed separately, stability improves when an Earth terminal of indicator / amplifier and a metal case of sensor connect to the nearest earth of each. But if they are apart far from each other, it may not bring a good result due to different electric potential of the earth. However, in such a case, stability improves if connecting a cable as Fig 2.

§ 3. Appearance and Each part name

Appearance of the unit

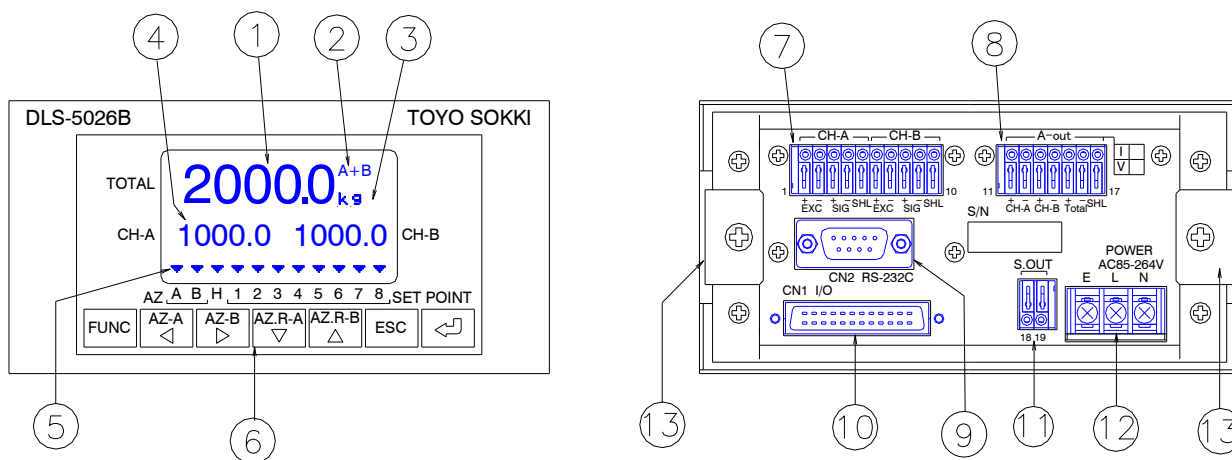

① Display of calculated value, TOTAL

② Status of calculated value, TOTAL

Status	Function
A+B	Calculated value CH-A+CH-B
A-B	" CH-A-CH-B

Set at [1 GENERAL FUNC / 5 TOTAL DISP] of Function Mode.

③ Display of unit

Set at [6 FCAL SETTING / 1 UNIT] of Function Mode.

Measured value is not converted even if the unit has been changed.

④ Display of measured value of CH-A and CH-B

⑤ Status display (11 kinds)

▼ Display	Status
AZ-A	Lighted ON during Tare subtraction of CH-A
AZ-B	Lighted ON during Tare subtraction of CH-B
H	Blinking during Hold operation
SET POINT 1 to 8	Lighted ON during comparator 1 to 8 is activated

⑥ Key Switch (7 keys)

Key	Operation in Measuring Mode	Operation in Function Mode
FUNC	Enter Function Mode when pushing for 1 second	No operation
AZ-A ◀	Perform Tare subtraction of CH-A when pushing for 1 sec.	Choose the classification in reverse order. At setting numerical value, select the digit toward left. At candidate choice, select a candidate in reverse order.
AZ-B	Perform Tare subtraction of CH-B when pushing for 1 sec.	Choose the classification in order.

▶		At setting numerical value, select the digit toward right.
		At candidate choice, select a candidate in order.
AZ.R-A ▼	Cancel Tare subtraction of CH-A when pushing for 1 sec.	Choose the item in classification in reverse order.
		At setting numerical value, decrease the numeric value of the selected digit.
AZ.R-B ▲	Cancel Tare subtraction of CH-B when pushing for 1 sec.	Choose the item in classification in order.
		At setting numerical value, increase the numeric value of the selected digit.
ESC	Perform Key Lock / Unlock when pushing for 2 seconds. (Lock / Unlock calibration when pushing 3 times immediately after powered ON)	Leave Function Mode. Cancel while setting.
ENT ↵	No operation.	Memorize the setting or the value

- ⑦ Load Cell input terminal
- ⑧ Analog output terminal (Prohibit connection when not installed OP-1/-2)
- ⑨ RS-232C serial connector (Available when installed OP-3)
- ⑩ External command input and output connector
- ⑪ Current loop output terminal
- ⑫ Power line terminal
- ⑬ Panel mount metal fitting

§ 4. Operation

4 – 1) Measuring Mode

1) Tare Subtraction

When pushing **AZ-A** or **AZ-B** key for 1 second, perform Tare subtraction of CH-A or CH-B. Appear a status ▼ mark on [AZ-A] or [AZ-B] during Tare subtracting. Push **AZ.R-A** or **AZ.R-B** key for 1 second to cancel Tare Subtraction of CH-A or CH-B. Tare value is memorized even after powered OFF.

2) Preset Tare Subtraction

This is used for an object that have a known container weight beforehand.

- ① Select a candidate [PRESET TARE] at [1 GENERAL FUNC / 3 NET CALC] of Function Mode.
- ② Set the numeric value at [1 GENERAL FUNC / 1 PreTare A or 2 PreTare B] of Function Mode. Setting range is 0~+99999.

Tare value is subtracted from the measured value afterwards if Preset Tare Subtraction has been set.

※ Please choose one either Preset Tare Subtraction or Net Calculation

3) Net Calculation

This is used for an object that have a known content amount beforehand.

- ① Select a candidate [NET] at [1 GENERAL FUNC/ 3 NET CALC] of Function Mode.
- ② Set the numerical value at [1 GENERAL FUNC / 1 PreTare A or 2 PreTare B] of Function Mode. Setting range is 0~+99999.
- ③ When **AZ-A** or **AZ-B** key is pushed during measurement, content amount of each channel appears on display and memorizes the value of subtracting content amount from the measured value.

※ Please choose one either Preset Tare Subtraction or Net Calculation

4) Hold

- ① Select a candidate of Hold type at [1 GENERAL FUNC / 4 HOLD MODE] of Function Mode.
- ② Select a candidate [HOLD] at [3 EXTERNAL INPUT / 1~8 EXT.IN1~8 ACTION] of Function Mode.
- ③ Connect an external switch to the terminal of the external input number chosen at ②. Interface of external input is mentioned at 7) in this section.
- ④ Perform Hold operation during External Command Input switch is ON.

During Peak Hold and Bottom Hold, the measured value is updated when data updates. Appear a status mark ▼ on [H] which is blinking during Hold operation.

5) Over Load

This is a function of alert for over-loading of Load Cell.

The measured value blinks to inform that it exceeds the preset rated capacity of Load Cell at [7 CH-A SETTING or 8 CH-B SETTING / 5 CAPACITY] of Function Mode.

Tare subtraction cannot be done during over-loaded.

6) Comparator Output

There are 8 comparators to output results of upper / lower judgement.
 Comparator conditions are set at [2 COMPARATOR] of Function Mode.

a) Comparator upper limit judgement

Output ON : Measured value \geq Quantitative value
 Output OFF : Measured value $<$ Quantitative value - Hysteresis value

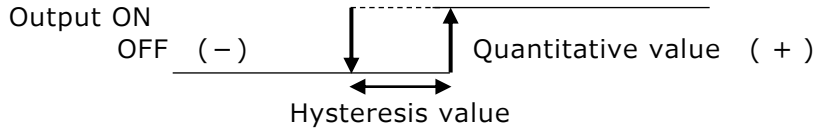

b) Comparator lower limit judgement

Output ON : Measured value \leq Quantitative value
 Output OFF : Measured value $>$ Quantitative value + Hysteresis value

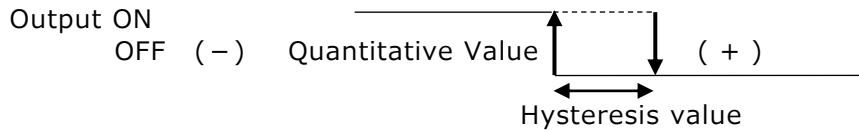

c) Delay Time

External output can be delayed after comparator perform upper / lower limit judgement.
 Select the numerical value 0.00 to 9.99 second at [2 COMPARATOR / 17~24 SP1~8 DELAY] of Function Mode

d) Abnormal Detection

Alert the operating conditions of this unit.
 Output ON when operating safe and normal and turns OFF in case of abnormal condition such as power supply failure or over loading.

e) Output Circuit Diagram

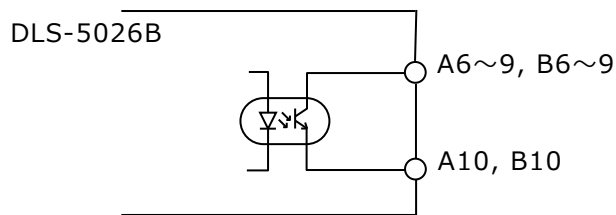

7) External Command Input

There are 8 photo couplers for external command Input
 Allocate a command to each input port at [3 EXTERNAL INPUT] of Function Mode.

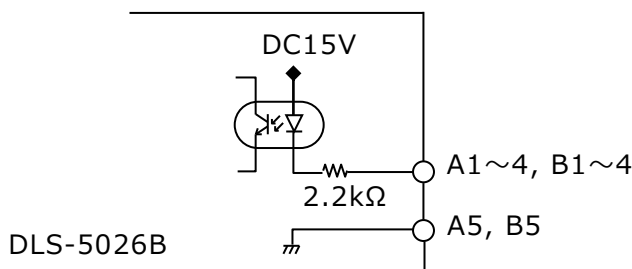

8) Key Lock

In order to prevent wrong operation, Key Lock function is available.

[KEY LOCKED] is displayed when pushing any key except **ESC** key in Key Lock status. But external input can be accepted.

Keys are locked after pushing **ESC** key for 2 seconds during Measuring Mode. To cancel Key Lock, push **ESC** key for 2 seconds again.

9) CAL Lock

This function prevents to change the span calibrated value from wrong operation.

(Re-calibration of zero point is possible even in CAL Lock status)

How to lock calibration.

- ① Push **ESC** key 3 times while turning on the power
- ② Select [CAL LOCK] or [CAL UNLOCK] by **◀** or **▶** key
- ③ Memorize by **ENT** key

10) Current Loop serial output

This function is a serial interface dedicated for a TOYO's peripheral equipment. If TOYO's CV-3010(serial to BCD converter) is connected to this interface, the measured value of this unit can be output as parallel BCD signal. Also an external indicator of TOYO can be connected to this interface.

This interface is isolated from an inner circuit and connected to an external equipment through 4 to 20mA current loop, thus less affected from noise and a cable can be extended up to 100m.

CV-3010 can be connected through RS-232C, but if the distance between this unit and CV-3010 is more than 15m, current loop interface should be used.

There is no function setting of this interface. Use a two-core cable and connect from output 'S.OUT' of this unit to input 'C/L' of external equipment. Two-core can be connected whichever as there is no polarity of them.

There is no use of a shielded cable in short distance, but wire apart from a power line or a drive motor line with noise.

4 – 2) Function Mode

This is a mode for various settings.

In order to enter Function Mode, Push **FUNC** key for 1 second during Measuring Mode.

Please refer a function table at §7.

4 – 3) Test Mode

This is a function to confirm the operation of this unit.

The response of indication and external input / output signal in Test Mode is different from Measuring Mode. Please take measures for connected external equipment to keep it from abnormality. Enter Test Mode by pushing **ENT** key 3 times immediately after powered ON or pushing **ENT** key 3 times in [11 TEST MODE] of the Function Mode.

§ 5. Calibration

As for the calibration method, there are two kinds of calibration, as [Equivalent Input Calibration] which input the equivalent output voltage of Load Cell by key operation, and as [Actual Load Calibration] which use a reference weight as an actual load. Calibration can be done by either method but it will be operated by the last calibration. Recommend to calibrate by an actual load as much as possible.

※Attention

- ① Number of figures are 5 digit (± 99999) on each of TOTAL, CH-A, CH-B indicator. If the measured value exceeds 5 digit (± 99999), '99999' will be blinking.
- ② Unit, Decimal point and Minimum scale is common to each of TOTAL, CH-A, CH-B.

5 – 1) Cancel Calibration Lock

There is a calibration lock function to keep the calibrated value secure from wrong operation. If span calibration is going to be performed, it is displayed [LOCK] during [CAL LOCK]. But zero point calibration can be done.

Please cancel [CAL LOCK] function prior to operate calibration.

	Guide display	Operation
1	(Power OFF)	Press [ESC] key 3 times within 3 sec. after power ON
2	CAL LOCK	Choose [CAL UNLOCK] by using ◀ or ▶ key
3		Memorize by pressing [ENT] key
4	(Measuring Mode)	Done

5 – 2) Preparation 1, prior to calibration (FCAL SETTING)













	Guide display	Operation
1	(Measuring Mode)	Enter Function Mode by pressing FUNC key
2	FUNCTION SELECT 1 GENERAL FUNC	Proceed to [6 FCAL SETTING] by pressing ▶ key
3	FUNCTION SELECT 6 FCAL SETTING	Proceed to the next item by pressing ▲ key
4	1 UNIT	Select a unit by using ◀ or ▶ key
5		Memorize by pressing ENT key
6		Proceed to the next item by pressing ▲ key.
7	2 DECIMAL POINT	Select decimal point position of the measured value by pressing ◀ or ▶ key
8		Memorize by pressing ENT key
9		Proceed to the next item by pressing ▲ key
10	3 MIN.DIV	Select minimum scale by pressing ◀ or ▶ key
11		Memorize by press ENT key
12		Return to [FUNCTION SELECT] by pressing ESC key
13	FUNCTION SELECT 6 FCAL SETTING	Proceed to [7 CH-A SETTING] by pressing ▶ key

5 – 3) Preparation 2, prior to calibration (CH-A SETTING)

	Guide display	Operation
1	FUNCTION SELECT 6 FCAL SETTING	Proceed to [7 CH-A SETTING] by pressing ▶ key
2	FUNCTION SELECT 7 CH-A SETTING	Proceed to the next item by pressing ▲ key
3	1 AVERAGE COND CH-A	Select condition of moving average by ◀ or ▶ key
4		Memorize by pressing ENT key
5		Proceed to the next item by pressing ▲ key
6	2 AVERAGE TIME CH-A	Select number of times of moving average by pressing ◀ or ▶ key
7		Memorize by pressing ENT key
8		Proceed to the next item by pressing ▲ key
9	3 ZT COND CH-A	Select condition of zero tracking by ◀ or ▶ key
10		Memorize by pressing ENT key
11		Proceed to the next item by pressing ▲ key
12	4 ZT TIME CH-A	Select working time of zero tracking by pressing ◀ or ▶ key
13		Memorize by pressing ENT key
14		Proceed to the next item by pressing ▲ key
15	5 CAPACITY CH-A	Set a rated capacity of Load Cell by using the following keys
16		◀ ▶ : Select a digit
17		▲ ▼ : Increase / decrease the value
18		Memorize by pressing ENT key
19	FUNCTION SELECT 7 CH-A SETTING	Return to [FUNCTION SELECT] by pressing ESC key
		Proceed to [8 CH-B SETTING] by pressing ▶ key

5 – 4) Preparation 3, prior to calibration (CH-B SETTING)
[8 CH-B SETTING] is also set as same as 5-3).

5 – 5) Calibration 1, by actual load calibration (CH-A CAL)





















	Guide display	Operation
1	FUNCTION SELECT 8 CH-B SETTING	Proceed to [9 CH-A CAL] by pressing  key
2	FUNCTION SELECT 9 CH-A CAL	Proceed to the next item by pressing  key
3	1 CAL 0 CH-A	Calibrate zero point. Confirm there is nothing on Load Cell
4		Press  key
5	(Value blinking)	Memorize by pressing  key
6		Proceed to the next item by pressing  key
7	2 CAL 1 CH-A	Put a weight as reference on Load Cell
8	(Value blinking)	Set a weight value by using the following keys   : Select a digit   : Increase / decrease the value
9		Memorize by pressing  key
10		Return to [FUNCTION SELECT] by pressing  key
11	FUNCTION SELECT 9 CH-A CAL	Proceed to [10 CH-B CAL] after pressing  key

5 – 6) Calibration 2, by actual load calibration (CH-B CAL)

[10 CH-B CAL] is also set as same as 5-5).

Return to Measuring Mode by pushing  key after completed calibration of both channels.

5 – 7) Calibration 1, by equivalent input calibration (CH-A CAL)

	Guide display	Operation
1	FUNCTION SELECT 8 CH-B SETTING	Proceed to [9 CH-A CAL] by pressing  key
2	FUNCTION SELECT 9 CH-A CAL	Proceed to [3 EQV 0.ADJ] by pressing  key
3	3 EQV 0.ADJ CH-A	Set zero voltage (mV/V) of Load Cell by using     key
4		Memorize by pressing  key
5		Proceed to the next item by pressing  key
6	4 EQV SPAN1 CH-A	Set display value of span amount by using     key
7		Memorize by pressing  key
8		Proceed to the next item by pressing  key
9	5 EQV SPAN ADJ1 CH-A	Set span voltage (mV/V) of Load Cell by using     key
10		Memorize by pressing  key
11		Return to [FUNCTION SELECT] by pressing  key
12	FUNCTION SELECT 9 CH-A CAL	Proceed to [10 CH-B CAL] by pressing  key

5 – 8) Calibration 2, by equivalent input calibration (CH-B CAL)

[10 CH-B CAL] is also set as same as 5-7).

Return to Measuring Mode by pressing  key after completed calibration of both channels.

§ 6. Option (Specified at the time of shipment)

Option (OP-1/2/3) can be installed at our factory. (Option at the time of shipment)
Analog output (OP-1 or OP-2) and RS-232C (OP-3) are able to be installed at the same time.

6 - 1) Analog Output (OP-1 / OP-2)

After A/D converting the input signal from Load Cell and amplifying it to an appropriate level, D/A converts it to analog output. By using a scaling function, TOTAL, CH-A and CH-B can output to 4~20mA as current signal (OP-1) or 0V~±10V as voltage signal (OP-2). In addition, it can be fine-tuned at 4mA, 20mA, 0V, +10V and -10V in order to regulate a level error against input of instruments connected to this unit. In Test Mode, it is possible to output 11 steps between 4~20mA or -10V~+10V.

1) OP-1: 4 to 20mA Current output. Scaling and fine tuning method

	Guide Display	Content	Operation
1	(Measuring Mode)		Enter Function Mode by pressing FUNC key
2	FUNCTION SELECT 1 GENERAL FUNC	Function Mode	Proceed to [4 AOUT SCALING] by pressing ▶ key
3	FUNCTION SELECT 4 AOUT SCALING	Set analog output	Proceed to the next item by using ▲ key
4	1 A. I SEL	Select CH-A output type	Select CH-A output type by ◀ ▶ key
5			Memorize by using ENT key
6			Proceed to the next item by pressing ▲ key
7	2 A. 4mA SCL	Scale 4mA output of CH-A	Set a display value to output 4mA of CH-A by using ◀ ▶ ▲ ▼ key
8			Memorize by using ENT key
9			Proceed to the next item by pressing ▲ key
10	3 A. 20mA SCL	Scale 20mA output of CH-A	Set a display value to output 20mA of CH-A by using ◀ ▶ ▲ ▼ key
11			Memorize by using ENT key
12			Proceed to the next item by pressing ▲ key
13	4 A. 4mA ADJ	Fine adjust 4mA output of CH-A	Fine adjust 4mA output of CH-A by using ◀ ▶ key. Tuning will be fast-forward ▶ or fast-rewind ◀ when the key pressed longer.
14			Memorize by using ENT key
15			Proceed to the next item by pressing ▲ key
16	5 A. 20mA ADJ	Fine adjust 20mA output of CH-A	Fine adjust 20mA output of CH-A by using ◀ ▶ key. Tuning will be fast-forward ▶ or fast-rewind ◀ when the key pressed longer.
17			Memorize by using ENT key
18			Proceed to the next item by pressing ▲ key
19	6 B. I SEL	Select CH-B output type	Perform setting CH-B output followed by the same procedure of the above 4 to 18
20	11 T. I SCL	Select TOTAL output type	Perform setting TOTAL output followed by the same procedure of the above 4 to 18
21	(Measuring Mode)		Return to Measuring Mode by pressing ESC key after the setting has been completed

2) OP-2: 0 to ±10V Voltage output. Scaling and fine tuning method

	Guide display	Content	Operation
1	(Measuring Mode)		Enter Function Mode by pressing FUNC key
2	FUNCTION SELECT 1 GENERAL FUNC	Function Mode	Proceed to [4 AOUT SCALING] by pressing ▶ key
3	FUNCTION SELECT 4 AOUT SCALING	Set analog output	Proceed to the next item by pressing ▲ key
4	1 A.V SEL	Select CH-A output type	Select CH-A output type by ◀ ▶ key
5			Memorize by using ENT key
6			Proceed to the next item by pressing ▲ key
7	2 A.0V SCL	Scale 0V output of CH-A	Set a display value to output 0V of CH-A by using ◀ ▶ ▲ ▼ key
8			Memorize by using ENT key
9			Proceed to the next item by pressing ▲ key
10	3 A.10V SCL	Scale 10V output of CH-A	Set a display value to output +10V of CH-A by using ◀ ▶ ▲ ▼ key
11			Memorize by using ENT key
12			Proceed to the next item by pressing ▲ key
13	4 A.0V ADJ	Fine adjust 0V output of CH-A	Fine adjust 0V output of CH-A by using ◀ ▶ key. Tuning will be fast-forward ▶ or fast-rewind ◀ when the key pressed longer.
14			Memorize by using ENT key
15			Proceed to the next item by pressing ▲ key
16	5 A.+10V ADJ	Fine adjust 10V output of CH-A	Fine adjust 10V output of CH-A by using ◀ ▶ key. Tuning will be fast-forward ▶ or fast-rewind ◀ when the key pressed longer.
17			Memorize by using ENT key
18			Proceed to the next item by pressing ▲ key
19	6 A.-10V ADJ	Fine adjust -10V output of CH-A	Fine adjust -10V output of CH-A by using ◀ ▶ key. Tuning will be fast-forward ▶ or fast-rewind ◀ when the key pressed longer.
20			Memorize by using ENT key
21			Proceed to the next item by pressing ▲ key
22	7 B.V SEL	Select CH-B output type	Perform setting CH-B output followed by the same procedure of the above 4 to 21
23	13 T. V SEL	Select TOTAL output type	Perform setting TOTAL output followed by the same procedure of the above 4 to 21
24	(Measuring Mode)		Return to Measuring Mode by pressing ESC key after the setting has been completed

6 – 2) RS-232C serial interface (OP-3)

In conformity of RS-232C serial interface, this unit can output serial data of bi-directional communication by the Half Duplex system.

1) Communication Protocol

ASC II code

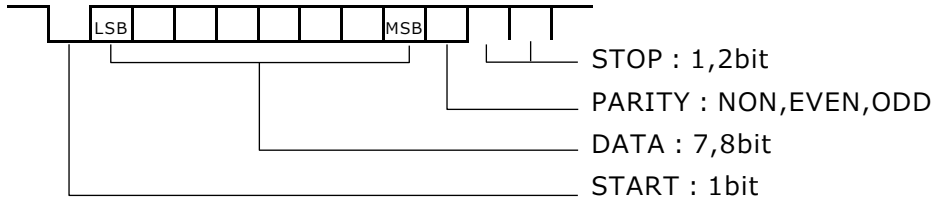

2) Communication Format

1	2	3	4	5	6	7	8	9	10	11	12
Header		,	TOTAL DATA							CR	LF

13	14	15	16	17	18	19	20	21	22	23	24	25	26	27
C	1	,	Header		,	CH-A DATA						CR	LF	

28	29	30	31	32	33	34	35	36	37	38	39	40	41	42
C	2	,	Header		,	CH-B DATA						CR	LF	

Terminator: CR = ODH, LF = OAH

	Header	
Normal Condition	W	T
Over Load	O	L

	DATA						
No decimal point	±	0	1	2	3	4	5
With decimal point	±	1	2	3	4	.	5
Over Load	±	9	9	9	9	.	9

3) I / F circuit diagram

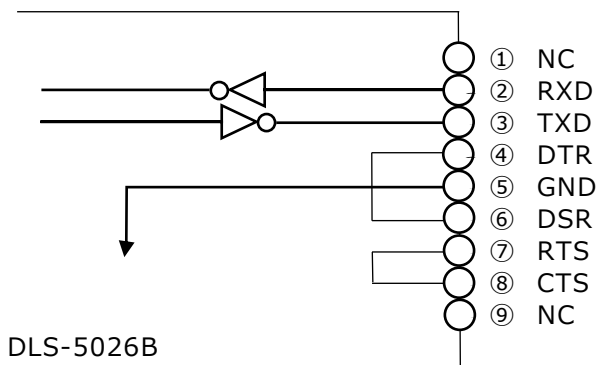

4) Communication command

Command	Correspondent	Number of digit	Function	Remarks
REQ	WT,±##### C1,WT,±##### C2,WT,±#####	6	Down-link demand	
C□,REQ	C□,WT,±#####	6	Down-link demand of Ch.□	□ = 0 to 2
DAZ	←	–	Tare Subtraction of all Ch.	
TRE	←	–		
AZR	←	–		
TRC	←	–		
C□,DAZ	←	–	Tare Subtraction of Ch.□	□ =1, 2
C□,TRE	←	–		
C□,AZR	←	–	Clear Tare Subtraction of Ch.□	□ =1, 2
C□,TRC	←	–		
C□,PTR	C□,PTR, +#####	6	Down-link demand of Preset Tare value of Ch.□	□ =1, 2
C□, PTR, +#####	←	6	Set a Preset Tare value of Ch.□	□ =1, 2 Forbid decimal point
SPn	SPn,±#####	6	Down-link demand of a Quantitative value of comparator n	n = 1 to 8
SPn,±#####	←	6	Set a Quantitative value of comparator n	n = 1 to 8 Forbid decimal point
HYn	HYn,+#####	6	Down-link demand of Hysteresis n.	n=1 to 8
HYn, +#####	←	6	Set Hysteresis n.	n=1 to 8 Forbid decimal point
DYn	DYn, +#####	6	Down-link demand of Delay time n.	n=1 to 8
DYn, + 000###	←	6	Set Delay time n. Remove decimal point x.xx → xxx 0.xx → 0xx 0.0x → 00x	n=1 to 8 Forbid decimal point Lower 3 digits are valid

Attach terminator < CR > <LF > to the last of each command.
 C□ : □ is 0=Calculated value(TOTAL), 1=CH-A, 2=CH-B.
 ##### : number of figures is including decimal point (with decimal point '1234.5', without decimal point '012345').
 Forbid decimal point when setting value. Decimal point attached when the down-link demand.

5) Error response

Error Code	Content	Remarks
ERR - 01	Memory error, writing error	Writing failure to nonvolatile memory, etc.
ERR - 02	Non implementation	Tare subtraction during over load, etc.
ERR - 05	Format abnormality	Undefined command, the number of the numerical value is incorrect, etc.

There is a terminator <CR> <LF> to the last of response.

§ 7. Function Mode

7 – 1) How to operate

- ① Enter Function Mode by pushing **FUNC** key for 1 second.
- ② Choice of large classification by using **◀** or **▶** key.
- ③ Choice of small classification by using **▲** or **▼** key.
- ④ Choice of digit or candidate by using **◀** or **▶** key.
- ⑤ When setting a numerical value, select the value by using **▲** or **▼** key.
- ⑥ When completed the setting, memorize by pushing **ENT** key.
- ⑦ Cancel the setting or leave Function Mode, push **ESC** key.

7 – 2) Function Table

1 GENERAL FUNC			
Guide Display	Content	Setting value/ candidates	Operation
1 PreTare A	Preset Tare value of A ch	0 to +99999	Set numerical value (0 at the time of shipment)
2 PreTare B	Preset Tare value of B ch	0 to +99999	Set numerical value (0 at the time of shipment)
3 NET CALC	Select NET calculation	PRESET TARE	Preset Tare Subtraction (at the time of shipment)
		NET	NET Calculation
4 HOLD MODE	Select Hold type	SAMPLE	Sample Hold (at the time of shipment)
		PEAK	Peak Hold
		BOTTOM	Bottom Hold
5 TOTAL DISP	Select TOTAL display	A+B	Net value of CH-A+CH-B (at the time of shipment)
		A-B	Net value of CH-A – CH-B
6 LANGUAGE	Select language	JAPANESE	Display in Japanese (at the time of shipment)
		ENGLISH	Display in English

2 COMPARATOR			
Guide display	Content	Setting value/ candidates	Operation
1 SP1 SET POINT	Quantitative value of comparator	-99999 to +99999	Set numerical value (+99999 at the time of shipment)
2 SP2 SET POINT			(-99999 at the time of shipment)
3 SP3 SET POINT			(+99999 at the time of shipment)
4 SP4 SET POINT			(-99999 at the time of shipment)
5 SP5 SET POINT			(+99999 at the time of shipment)
6 SP6 SET POINT			(-99999 at the time of shipment)
7 SP7 SET POINT			(+99999 at the time of shipment)
8 SP8 SET POINT			(-99999 at the time of shipment)
9 SP1 HYS	Hysteresis of comparator	0 to 99999	Set numerical value (0 at the time of shipment)
10 SP2 HYS			
11 SP3 HYS			
12 SP4 HYS			
13 SP5 HYS			
14 SP6 HYS			
15 SP7 HYS			
16 SP8 HYS			
17 SP1 DELAY	Delay output of comparator	0.00 sec to 9.99 sec	Set numerical value (0.00sec at the time of shipment)
18 SP2 DELAY			
19 SP3 DELAY			

20 SP4 DELAY	Select judgement of comparator	NONE	Do not judge. No output.		
21 SP5 DELAY					
22 SP6 DELAY					
23 SP7 DELAY					
24 SP8 DELAY					
25 SP1 MOTION					
26 SP2 MOTION				A NET UPPER LMT	Upper limit of Net value of CH-A (SP1 at the time of shipment)
27 SP3 MOTION				A NET LOWER LMT	Lower limit of Net value of CH-A (SP2 at the time of shipment)
28 SP4 MOTION				A GRS UPPER LMT	Upper limit of Gross value of CH-A
29 SP5 MOTION				A GRS LOWER LMT	Lower limit of Gross value of CH-A
30 SP6 MOTION				B NET UPPER LMT	Upper limit of Net value of CH-B (SP3 at the time of shipment)
31 SP7 MOTION				B NET LOWER LMT	Lower limit of Net value of CH-B (SP4 at the time of shipment)
32 SP8 MOTION				B GRS UPPER LMT	Upper limit of Gross value of CH-B
				B GRS LOWER LMT	Lower limit of Gross value of CH-B
	A+B UPPER LMT	Upper limit of calculated value of CH-A+CH-B (SP5 at the time of shipment)			
	A+B LOWER LMT	Lower limit of calculated value of CH-A+CH-B (SP6 at the time of shipment)			
	A-B UPPER LMT	Upper limit of calculated value of CH-A-CH-B (SP7 at the time of shipment)			
	A-B LOWER LMT	Lower limit of calculated value of CH-A-CH-B (SP8 at the time of shipment)			
	ABNORMAL	Output ON during normal operation			

3 EXTERNAL INPUT			
Guide display	Content	Setting candidates	Operation
1 EXT.IN1 ACTION	Select operation of external command input	NONE	No operation (EXT.IN8 at the time of shipment)
2 EXT.IN2 ACTION		AZ-A	Tare subtraction of CH-A (EXT.IN1 at the time of shipment)
3 EXT.IN3 ACTION		AZ-B	Tare subtraction of CH-B (EXT.IN3 at the time of shipment)
4 EXT.IN4 ACTION		AZ-TOTAL	Tare subtraction of TOTAL (EXT.IN5 at the time of shipment)
5 EXT.IN5 ACTION		AZR-A	Cancel Tare subtraction of CH-A (EXT.IN2 at the time of shipment)
6 EXT.IN6 ACTION		AZR-B	Cancel Tare subtraction of CH-B (EXT.IN4 at the time of shipment)
7 EXT.IN7 ACTION		AZR-TOTAL	Cancel Tare subtraction of TOTAL (EXT.IN6 at the time of shipment)
8 EXT.IN8 ACTION		HOLD	Hold during Low level (EXT.IN7 at the time of shipment)

4 AOUT SCALING ※ Effective when OP-1 / OP-2 installed			
Guide display	Content	Setting value /candidates	Operation
[OP-1: 4~20mA current output]			
1 A. I SEL	CH-A Output data type	NET	Output Net value (at the time of shipment)
		GROSS	Output Gross value
2 A. 4mA SCL	CH-A Scale to output 4mA	-99999 to +99999	Numeric value setting (0 at the time of shipment)
3 A. 20mA SCL	CH-A Scale to output 20mA	-99999 to +99999	Numeric value setting (10000 at the time of shipment)
4 A. 4mA ADJ	CH-A Fine adjustment of 4mA output	-999 to +999	Candidate selection (0 at the time of shipment)
5 A. 20mA ADJ	CH-A Fine adjustment of 20mA output	-999 to +999	Candidate selection (0 at the time of shipment)
6 B. I SEL	CH-B Output data type	NET	Output Net value (at the time of shipment)
		GROSS	Output Gross value
7 B. 4mA SCL	CH-B Scale to output 4mA	-99999 to +99999	Numeric value setting (0 at the time of shipment)
8 B. 20mA SCL	CH-B Scale to output 20mA	-99999 to +99999	Numeric value setting (10000 at the time of shipment)
9 B. 4mA ADJ	CH-B Fine adjustment of 4mA output	-999 to +999	Candidate selection (0 at the time of shipment)
10 B. 20mA ADJ	CH-B Fine adjustment of 20mA output	-999 to +999	Candidate selection (0 at the time of shipment)
11 T. I SEL	TOTAL Output data type	A+B	Output calculated value A+B (at the time of shipment)
		A-B	Output calculated value A-B
12 T. 4mA SCL	TOTAL Scale to output 4mA	-99999 to +99999	Numeric value setting (0 at the time of shipment)
13 T. 20mA SCL	TOTAL Scale to output 20mA	-99999 to +99999	Numeric value setting (10000 at the time of shipment)
14 T. 4mA ADJ	TOTAL Fine adjustment of 4mA output	-999 to +999	Candidate selection (0 at the time of shipment)
15 T. 20mA ADJ	TOTAL Fine adjustment of 20mA output	-999 to +999	Candidate selection (0 at the time of shipment)

Guide display	Content	Setting value /candidates	Operation
[OP-2: 0~±10V voltage output]			
1 A. V SEL	CH-A Output data type	NET	Output Net value (at the time of shipment)
		GROSS	Output Gross value
2 A. 0V SCL	CH-A Scale to output 0V	-99999 to +99999	Numeric value setting (0 at the time of shipment)
3 A.10V SCL	CH-A Scale to output 10V	-99999 to +99999	Numeric value setting (10000 at the time of shipment)

4	A.0V ADJ	CH-A Fine adjustment of 0V output	-999 to +999	Candidate selection (0 at the time of shipment)
5	A. +10V ADJ	CH-A Fine adjustment of 10V output	-999 to +999	Candidate selection (0 at the time of shipment)
6	A. -10V ADJ	CH-A Fine adjustment of -10V output	-999 to +999	Candidate selection (0 at the time of shipment)
7	B. V SEL	CH-B Output data type	NET	Output Net value (at the time of shipment)
			GROSS	Output Gross value
8	B.0V SCL	CH-B Scale to output 0V	-99999 to +99999	Numeric value setting (0 at the time of shipment)
9	B. 10V SCL	CH-B Scale to output 10V	-99999 to +99999	Numeric value setting (10000 at the time of shipment)
10	B. 0V ADJ	CH-B Fine adjustment of 0V output	-999 to +999	Candidate selection (0 at the time of shipment)
11	B. +10V ADJ	CH-B Fine adjustment of 10V output	-999 to +999	Candidate selection (0 at the time of shipment)
12	B. -10V ADJ	CH-B Fine adjustment of -10V output	-999 to +999	Candidate selection (0 at the time of shipment)
13	T. V SEL	TOTAL Output data type	A+B	Output calculated value A+B (at the time of shipment)
			A-B	Output calculated value A-B
14	T. 0V SCL	TOTAL Scale to output 0V	-99999 to +99999	Numeric value setting (0 at the time of shipment)
15	T. 10V SCL	TOTAL Scale to output 10V	-99999 to +99999	Numeric value setting (10000 at the time of shipment)
16	T. 0V ADJ	TOTAL Fine adjustment of 0V output	-999 to +999	Candidate selection (0 at the time of shipment)
17	T. +10V ADJ	TOTAL Fine adjustment of 10V output	-999 to +999	Candidate selection (0 at the time of shipment)
18	T. -10V ADJ	TOTAL Fine adjustment of -10V output	-999 to +999	Candidate selection (0 at the time of shipment)

5 COMM SETTING			
Guide Display	Content	Setting candidates	Operation
1	COMM MODE	Communication type	STREAM Transmit only (at the time of shipment)
			COMMAND Transmit and Receive by command communication
2	DATA	Output data type	NET A+B Calculated value of CH-A+CH-B + Net value of CH-A and CH-B (at the time of shipment)
			NET A-B Calculated value of CH-A-CH-B + NET value of CH-A and CH-B
			GRS A+B Calculated value of CH-A+CH-B + Gross value of CH-A and CH-B

		GRS A – B	Calculated value of CH-A–CH-B + Gross value of CH-A and CH-B
3 BAUD RATE	Baud rate	2400bps	2400bps (at the time of shipment)
		4800bps	4800bps
		9600bps	9600bps
		19200bps	19200bps
4 PROTOCOL	Communication protocol	7bit, none, 1bit	7bit length, no parity, 1stop bit
		7bit, even, 1bit	7bit length, even parity, 1stop bit
		7bit, odd, 1bit	7bit length, odd parity, 1stop bit
		8bit, none, 1bit	8bit length, no parity, 1stop bit
		8bit, even, 1bit	8bit length, even parity, 1stop bit
		8bit, odd, 1bit	8bit length, odd parity, 1stop bit
		7bit, none, 2bit	7bit length, no parity, 2stop bit
		7bit, even, 2bit	7bit length, even parity, 2stop bit (at the time of shipment)
		7bit, odd, 2bit	7bit length, odd parity, 2stop bit
		8bit, none, 2bit	8bit length, no parity, 2stop bit
		8bit, even, 2bit	8bit length, even parity, 2stop bit
		8bit, odd, 2bit	8bit length, odd parity, 2stop bit

6 FCAL SETTING			
Guide display	Content	Setting candidates	Operation
1 UNIT	Display unit (common to CH-A/-B and TOTAL)	None	Do not display unit
		g	Gram
		kg	Kilo gram (at the time of shipment)
		T	Ton
		N	Newton
		kN	Kilo newton
		N·m	Newton·meter
		kN·m	Kilo newton·meter
		Pa	Pascal
		kPa	Kilo pascal
		MPa	Mega pascal
		mm	Millimeter
		%	Percentage
		με	Micro strain
mV/V	Millivolt per volt		
2 DECIMAL POINT	Decimal point position (common to CH-A/-B and TOTAL)	0	No decimal point (at the time of shipment)
		0.0	1 digit after decimal point
		0.00	2 digit after decimal point
		0.000	3 digit after decimal point
		0.0000	4 digit after decimal point
3 MIN.DIV	Minimum scale (common to CH-A/-B and TOTAL)	1	Minimum scale 1 (at the time of shipment)
		2	Minimum scale 2
		5	Minimum scale 5
		10	Minimum scale 10
		20	Minimum scale 20
		50	Minimum scale 50
		100	Minimum scale 100

7 CH-A SETTING			
Guide display	Content	Setting value /candidates	Operation
1 AVERAGE COND CH-A	Condition of moving average	OFF	Normal moving average (at the time of shipment)
		5d	Moving average range of ± 5 scale
		10d	ditto ± 10 scale
		20d	ditto ± 20 scale
		50d	ditto ± 50 scale
		100d	ditto ± 100 scale
		200d	ditto ± 200 scale
		500d	ditto ± 500 scale
2 AVERAGE TIME CH-A	Number of times of moving average	1t	1 time (No average)
		4t	4 times
		8t	8 times
		16t	16 times
		32t	32 times (at the time of shipment)
		64t	64 times
		128t	128 times
		256t	256 times
3 ZT COND CH-A	Condition of zero tracking	OFF	Zero tracking ineffective (at the time of shipment)
		1d	Within ± 1 scale
		2d	Within ± 2 scale
		3d	Within ± 3 scale
		4d	Within ± 4 scale
		5d	Within ± 5 scale
		10d	Within ± 10 scale
4 ZT TIME CH-A	Working time of zero tracking	0.02s	0.02 second
		0.1s	0.1 second
		0.5s	0.5 second
		1.0s	1.0 second (at the time of shipment)
		2.0s	2.0 seconds
		3.0s	3.0 seconds
5 CAPACITY CH-A	Rated capacity of Load Cell	0 to +99999	Setting numerical value (+99999 at the time of shipment)

8 CH-B SETTING			
Guide display	Content	Setting value /candidates	Operation
1 AVERAGE COND CH-B	Condition of moving average	OFF	Normal moving average (at the time of shipment)
		5d	Moving average range of ± 5 scale
		10d	ditto ± 10 scale
		20d	ditto ± 20 scale
		50d	ditto ± 50 scale
		100d	ditto ± 100 scale
		200d	ditto ± 200 scale
		500d	ditto ± 500 scale
2 AVERAGE TIME CH-B	Number of times of moving average	1t	1 time (No average)
		4t	4 times
		8t	8 times
		16t	16 times
		32t	32 times (at the time of shipment)

		64t	64 times
		128t	128 times
		256t	256 times
3 ZT COND CH-B	Condition of zero tracking	OFF	Zero tracking ineffective (at the time of shipment)
		1d	Within ± 1 scale
		2d	Within ± 2 scale
		3d	Within ± 3 scale
		4d	Within ± 4 scale
		5d	Within ± 5 scale
		10d	Within ± 10 scale
4 ZT TIME CH-B	Working time of zero tracking	0.02s	0.02 second
		0.1s	0.1 second
		0.5s	0.5 second
		1.0s	1.0 second (at the time of shipment)
		2.0s	2.0 seconds
		3.0s	3.0 seconds
5 CAPACITY CH-B	Rated capacity of Load Cell	0 to +99999	Setting numeric value (+99999 at the time of shipment)

9 CH-A CAL			
Guide display	Content	Setting value	Operation
1 CAL 0 CH-A	Zero point actual load calibration	0	Fixed setting value '0'
2 CAL 1 CH-A	Span1 actual load calibration	-99999 to +99999	Setting numeric value (10000 at the time of shipment)
3 EQV 0.ADJ CH-A	Zero point value of Load Cell	-3.0000 to +3.0000	Setting numeric value (mV/V) (0.0000 at the time of shipment)
4 EQV SPAN1 CH-A	Display value of span1	-99999 to +99999	Setting numeric value (10000 at the time of shipment)
5 EQV SPAN ADJ1 CH-A	Span1 value of Load Cell	-3.0000 to +3.0000	Setting numeric value (mV/V) (1.0000 at the time of shipment)

10 CH-B CAL			
Guide display	Content	Setting value	Operation
1 CAL 0 CH-B	Zero point actual load calibration	0	Fixed setting value '0'
2 CAL 1 CH-B	Span1 actual load calibration	-99999 to +99999	Setting numeric value (10000 at the time of shipment)
3 EQV 0.ADJ CH-B	Zero point value of Load Cell	-3.0000 to +3.0000	Setting numeric value (mV/V) (0.0000 at the time of shipment)
4 EQV SPAN1 CH-B	Display value of span1	-99999 to +99999	Setting numeric value (10000 at the time of shipment)
5 EQV SPAN ADJ1 CH-B	Span1 value of Load Cell	-3.0000 to +3.0000	Setting numeric value (mV/V) (1.0000 at the time of shipment)

11 TEST Mode			
Guide display	Content	Setting value	Operation
11 TEST MODE	Shift to Test Mode	-	Press ENT key 3 times

§ 8. Test Mode

※The response of external I/O signal and indication of display is different during Test Mode. Please take measures to connected external equipment to keep it from abnormality. Test Mode confirms conditions of this unit by manual operation.

8 – 1) Operation method

- 1) To enter Test Mode, push **[ENT]** key 3 times immediately after powered ON or push **[ENT]** key 3 times at [11 TEST MODE] of Function Mode.
- 2) Push **[▲]** key to proceed to the next item. Push **[▼]** key to return to the previous item.

8 – 2) Test item

	Guide Display	Content	Description
1	MODEL NAME	DLS-5026B	[▲] key to the next item [▼] key to the previous item
2	PROGRAM VER	Program version P-x.xx	[▲] key to the next item [▼] key to the previous item
3	DISPLAY CHECK	Check lighting of VFD display	Whenever pushing [◀] or [▶] key, Display guidance ⇔ All OFF ⇔ All ON [▲] to the next item, [▼] to the previous item
4	KEY CHECK	Check keys	Indicate ○ → ● when the key pushed Push [▲] key 2 times to the next item Push [▼] key 2 times to the previous item
5	EXT.IN CHECK	Check external command input	Indicate ○ → ● when external input ON [▲] to the next item [▼] to the previous item
6	EXT.OUT CHECK	Check external output	Select external output by [◀] or [▶] key Correspondent mark indicate ○ → ● [▲] to the next item, [▼] to the previous item
7	A.OUT CHECK	Check current output ※ effective when OP-1 installed	Increase / Decrease output by [◀] or [▶] key, 11 steps Output channel is changed by [FUNC] key [▲] to the next item, [▼] to the previous item
		Check voltage output ※ effective when OP-2 installed	Increase / Decrease output by [◀] or [▶] key, 11 steps Output channel is changed by [FUNC] key [▲] to the next item, [▼] to the previous item
8	SERIAL CHECK	Check RS-232C communication	Output by [◀] or [▶] key [REQ] command is accepted to output data ※Fixed: 2400bps, 7bit, even, 2stop bit [▲] to the next item, [▼] to the previous item
9	SENSOR CHECK	Check input voltage from Load Cell	[◀] : Zero, [▶] : Cancel zero Input channel is changed by [FUNC] key [▲] to the next item, [▼] to the previous item
10	RESTART	Leave Test Mode	Select [RESET ON/OFF] by [◀] or [▶] key Decide by [ENT] key [▲] to the next item, [▼] to the previous item

§ 9. Troubleshooting

If this unit does not work properly, please take the following measures. If the trouble still cannot be solved, then please contact our company.

At query, please inform us the model name, product serial number, and conditions of this unit as detailed as possible. The model name of Load Cell or a sensor connected to this unit should be also informed.

9 – 1) Basic check point

- 1) Please check if using a correct power supply.
This unit is supplied voltage with AC100 to 240V.
- 2) Please check that wires are connected to the terminal base properly and firmly.

9 – 2) Precautions at the time of calibration.

1) Error occurs at the time of zero calibration.

•In case of exceeding the range of zero calibration.

To perform zero point calibration, Load Cell output with no load should be in the range of $-2.8 \sim +2.8 \text{ mV/V}$. Please call us if it is out of the range of $\pm 2.8 \text{ mV/V}$, when using Load Cell whose rated output is more than 3.3 mV/V .

2) Error occurs at the time of span calibration, or display value is not correct as set in span calibration.

•In case of a sensor output being higher.

This unit cannot measure in a system that the sum of initial tare value and measured value exceed 3.3 mV/V . Please contact us when the rating output of the sensor is more than 3.3 mV/V .

•In case of input level of span calibration being lower.

This unit cannot calibrate span when span amount of output of Load Cell is lower than value set at [CH-x CAL / 2 CAL 1]. Increase minimum scale at [6 FCAL SETTING / 3 MIN.DIV] to make resolution rougher or use an appropriate Load Cell.

3) Fluctuation of indication

•In case of span amount against resolution being not enough.

The input sensitivity of this unit is $0.25 \mu\text{V}/\text{digit}$ and indication resolution is $1/20,000$ at 1.0 mV/V input. If the resolution is more than this, fluctuation of indication becomes bigger. In this case, please increase minimum scale at [6 FCAL SETTING / 3 MIN.DIV] until not to be noticeable of fluctuation.

9 – 3) Countermeasure when abnormal display is indicated

In case of the measured value blinking when not overloaded. Causes are considered as follows.

- ① Disconnection of sensor cable
- ② Sensor failure

Please confirm input signal from a sensor at [11 TEST MODE / 9 SENSOR CHECK] in Test Mode.

9 – 4) Judgement whether this unit has malfunction

- 1) Please confirm whether sensor excitation voltage is correct. Please disconnect sensor from this unit and check the voltage by a tester between #1(+EXC) and #2(-EXC) of terminal, #6-#7, #11-#12 or #16-#17 are stable at $5\text{V} \pm 0.5\text{V}$. If it is not stable, this unit should have malfunction.
- 2) Make electrical short between #3(+SIG) and #4(-SIG) of terminal, #8-#9, #13-#14, #18-#19 (make input voltage 0V). Check input voltage at [11 TEST MODE / 9 SENSOR CHECK]. Please confirm whether it is stable at around 0.0000 mV/V . If it is not stable, this unit should have malfunction. If it is stable, please check a sensor or sensor cable.

3) Digital I/O check

Please perform I/O check at [11 TEST MODE / 5 EXT.IN CHEK or 6 EXT.OUT CHECK] in Test Mode.

9 – 5) Checking Sensor (Load Cell)

Good or bad rough judgement can be done by measuring input/output resistance and insulation resistance because the Load Cell is structured by a bridge circuit.

(Please make sure to power OFF this unit first and disconnect Load Cell before checking resistance)

1) Fault judging method by resistance of Load Cell.

Check bridge resistance of Load Cell by a tester, and confirm whether input/output resistance are correct.

2) Fault judging method by insulation resistance of Load Cell.

Measure insulation resistance between shield line and other with voltage less than 50V. If the insulation resistance has more than 1000M Ω , insulation of Load Cell is no problem.

§ 1 0 . Specifications

1 0 – 1) A/D convert part

- | | |
|--|---|
| 1) Transducer input | 2 channels |
| 2) Minimum input sensitivity | 0.25 μ V/digit
(Maximum resolution 1/20,000 at 1.0mV/V input) |
| 3) Non-linearity | $\pm 0.02\%$ FS ± 1 count |
| 4) Temp. characteristic zero point sensitivity | $\pm 0.005\%$ FS/ $^{\circ}$ C (at 1.0mV/V input)
$\pm 0.005\%$ Reading / $^{\circ}$ C |
| 5) Frequency response | approx. 2Hz (at moving average 32 times) |
| 6) Sampling period | approx. 10ms (100 times/second)
synchronized between channels |
| 7) Power for transducer | 5V $\pm 5\%$, 60mA : each channel
(able to connect 4 sensors of 350 Ω) |

1 0 – 2) Display part

- | | |
|----------------------------------|---|
| 1) Display device | Graphic Fluorescence indication pipe. 128 x 64 dot
Green back light |
| 2) Indication of measuring level | |
| ① Calculated value display | 5 digit (± 99999), Letter height approx. 12mm |
| ② Measured value display A | 5 digit (± 99999), Letter height approx. 6mm |
| ③ Measured value display B | 5 digit (± 99999), Letter height approx. 6mm |
| ④ Status display | ▼ mark 11pcs, AZ-A, AZ-B, HOLD, SET POINT 1 to 8 |
| 3) Over load | Blinking when the measured value exceeds capacity |
| 4) Decimal point | 0 (Nil), 0.0, 0.00, 0.000, 0.0000 |
| 5) Unit display | Nil, g, kg, t, N, kN, N \cdot m, kN \cdot m, Pa, kPa, MPa, mm, %, μ ϵ , mV/V |
| 6) Display update period | approx. 100ms (10 times/second) |

1 0 – 3) Zero point and sensitivity adjustment

- | | |
|---------------------------|---|
| 1) Zero point adjustment | adjustable within the range of ± 2.8 mV/V input |
| 2) Sensitivity adjustment | adjustable within the range of ± 0.4 to ± 3.0 mV/V input |
| | ※ Sum of initial Tare level (zero point input value) and the maximum measured level (span amount) must not exceed ± 3.3 mV/V. |
| 3) Calibration method | Actual load method and Equivalent input method |

1 0 – 4) I/O part

- | | |
|---------------------------|--|
| 1) Operation switch | 7 keys
Item selection key : FUNC
Operation key : AZ-A, AZ-B, AZ.R-A, AZ.R-B
(function as arrow key when setting)
ESCAPE key : ESC
ENTRY key : ENT |
| 2) External command input | |
| ① Input signal | 8 point (8 bit, 1 common)
Contact input without voltage or Open collector input
(Ic = 10mA, Voltage endurance more than 20V) |
| ② Operation | (a) AZ-A : One shot MAKE contact (Pulse width 0.2 second) |
| | (b) AZ.R-A : ditto |
| | (c) AZ-B : ditto |
| | (d) AZ.R-B : ditto |

- (e) AZ-TOTAL : ditto
- (f) AZ.R-TOTAL : ditto
- (g) HOLD : Level control Low = Hold / High = Cancel

3) External output

- ① Output signal 8 point (8 bit, 1 common).
Open collector output with common emitter, negative logic (NPN transistor).
- ② Rated output DC30V, 50mA (Resistance load).
Saturation voltage between collector and emitter should be less than 1.2V.
Isolated from an internal circuit by a photo coupler.

4) Current loop output

Serial data interface for exclusive use of TOYO's external peripheral equipment

1 0 – 5) Option

1) OP-1 : 4 to 20mA current output

- ① Number of output channels 3 channels (measured value A, B and calculated value TOTAL). Isolated output.
- ② Resolution Linked with display resolution (Max. 1/40,000)
- ③ Output range approx. 0 to 24mA
- ④ Load resistance 0 to 510Ω
- ⑤ Update period Synchronized with sampling
- ⑥ Non linearity ±0.05% FS (for display level)
- ⑦ Temperature characteristics Zero point, Sensitivity= ±0.02% FS/°C typ. (for display level)

2) OP-2 : 0 to ±10V voltage output

- ① Number of output channels 3 channels (measured value A, B and calculated value TOTAL). Isolated output
- ② Resolution Linked with display resolution (Max. 1/40,000)
- ③ Output range approx. -12.0V to 12.0V
- ④ Load resistance ≥5kΩ
- ⑤ Update period Synchronized with sampling
- ⑥ Non linearity ±0.05%FS (for display level)
- ⑦ Temperature characteristics Zero point, Sensitivity= ±0.02%FS/°C typ. (for display level)

3) OP-3 : RS-232C serial data interface

- ① Communication standard EIA RS-232C conformity. Isolated I/O.
- ② Communication method Start-Stop Synchronous (Asynchronous) type / Half-duplex bi-directional
- ③ Communication speed 2400, 4800, 9600, 19200bps
- ④ Communication protocol Data bit: 7, 8/ Stop bit:1, 2/ Parity: NON, EVEN, ODD
Data: ASCII Code
- ⑤ Communication format TOYO dedicated format

1 0 – 6) General

- 1) Countermeasure of power failure Setting data are memorized to a non-volatile memory
- 2) Power supplied voltage AC85 to 264V, 50/60Hz
- 3) Consumption current 0.6A typ. (AC IN 100V)
0.4A typ. (AC IN 200V)
- 4) Range of temp. & humidity 0 to +40°C, 20 to 85% R.H. (No condensation)
- 5) Mounting method Panel mount type
- 6) Mass approx. 1.1kg

§ 1 1. List of Models and Accessories

1 1 – 1) Model

DLS – 5026B – □

Option Blank : No option

1 : OP-1 4 to 20mA current output

2 : OP-2 0 to ±10V voltage output

3 : OP-3 RS-232C serial interface

Product model name

※ Installing an option is only available in the manufacturer before shipment.
(Option at the time of shipment)

It is possible to install with either OP-1 or OP-2 and OP-3 at the same time

1 1 – 2) Accessories

- | | |
|--|--------|
| 1) Operation manual | 1 copy |
| 2) Terminal plate cover (for power line) | 1 pc |
| 3) 24 pin connector for I/O signal (FCN-361J024 and cover) | 1 pc |

§ 1 2. Terminal Layout

1) Load Cell input terminal (3.81mm pitch, screw less)

No.	Connection Signal		
1	EXC+	Excitation voltage to Load Cell (+)	CH-A
2	EXC-	Excitation voltage to Load Cell (-)	
3	SIG+	Input signal from Load Cell (+)	
4	SIG-	Input signal from Load Cell (-)	
5	SHL	Shield line of Load Cell	
6	EXC+	Excitation voltage to Load Cell (+)	CH-B
7	EXC-	Excitation voltage to Load Cell (-)	
8	SIG+	Input signal from Load Cell (+)	
9	SIG-	Input signal from Load Cell (-)	
10	SHL	Shield line of Load Cell	

Note:
A shield line of each cables should be grounded to one of either this unit or the connected equipment.

Applicable wire range

Single wire = $\Phi 0.4 \sim 1.2\text{mm}$ (AWG26~16)

Strand wire = $0.2 \sim 0.75\text{mm}^2$ (AWG24~20), wire OD $\geq \Phi 0.18\text{mm}$

Standard peeled wire length : 9~10mm

Use a 4-core shielded cable and wire apart from a power line or a motor drive line with noise to prevent malfunction.

The cable wiring color varies depending on the manufacturer or a model. Refer to the Test Report attached to Load Cell, check the signal name and color, and connect correctly and firmly.

2) Analog output terminal (3.81mm pitch, screw less)

Do not connect any wire when not installed analog output option, OP-1/OP-2

No.	Connection Signal	
11	CH-A+	Current or Voltage of CH-A (+)
12	CH-A-	Current or Voltage of CH-A (-)
13	CH-B+	Current or Voltage of CH-B (+)
14	CH-B-	Current or Voltage of CH-B (-)
15	TOTAL+	Current or Voltage of TOTAL (+)
16	TOTAL-	Current or Voltage of TOTAL (-)
17	SHL	Shield line of analog output

Applicable wire range

Single wire = $\Phi 0.4 \sim 1.2\text{mm}$ (AWG26~16)

Strand wire = $0.2 \sim 0.75\text{mm}^2$ (AWG24~20), wire OD $\geq \Phi 0.18\text{mm}$

Standard peeled wire length: 9~10mm

3) Current Loop output terminal (3.81mm pitch, screw less)

No.	Connection Signal	
18	S.OUT	Current Loop output (No Polarity)
19	S.OUT	

Applicable wire range

Single wire = $\Phi 0.4 \sim 1.2\text{mm}$ (AWG26~16)

Strand wire = $0.2 \sim 0.75\text{mm}^2$ (AWG24~20), wire OD $\geq \Phi 0.18\text{mm}$

Standard peeled wire length : 9~10mm

4) Power line terminal (7.62mm pitch for crimped terminal)

No.	Connection Signal	
20	E	Earth (Ground)
21	L	Power line AC100 to 240V
22	N	

Crimped terminal spec. : M3 with a width of maximum 6mm

Earth terminal (E) should be connected to the ground resistance $\leq 100\Omega$

- 5) RS-232C serial interface terminal (D-SUB 9 pin / male)
Available when OP-3, RS-232C serial interface is installed

No.	Connection Signal	
1	NC	
2	RXD	Receive data
3	TXD	Transmit data
4	DTR	Data terminal ready
5	GND	Signal ground
6	DSR	Data set ready
7	RTS	Request to send
8	CTS	Clear to send
9	NC	

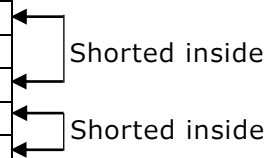

Shorted inside
Shorted inside

- 6) External Command Input / Output terminal (FCN-360 type)

Connection Signal		No.	No.	Connection Signal	
External Command Input 1	IN1	A1	B1	IN2	External Command Input 2
External Command Input 3	IN3	A2	B2	IN4	External Command Input 4
External Command Input 5	IN5	A3	B3	IN6	External Command Input 6
External Command Input 7	IN7	A4	B4	IN8	External Command Input 8
External Command Input Common GND	CMD. COM	A5	B5	CMD. COM	External Command Input Common GND
Comparator Output 1	OUT1	A6	B6	OUT2	Comparator Output 2
Comparator Output 3	OUT3	A7	B7	OUT4	Comparator Output 4
Comparator Output 5	OUT5	A8	B8	OUT6	Comparator Output 6
Comparator Output 7	OUT7	A9	B9	OUT8	Comparator Output 8
Comparator Output Common Emitter	E. COM	A10	B10	E. COM	Comparator Output Common Emitter
	NC	A11	B11	NC	
Shield	SHL	A12	B12	SHL	Shield

Applicable Connector (24 pin connector) : Fujitsu FCN361J024

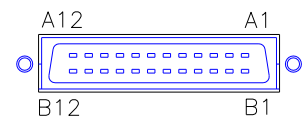

The shield line of the cable should be grounded to the other unit which is connected to. When grounding the shield line to this unit, A12 and B12 terminal should be used.

§ 1 3. Dimensional drawing

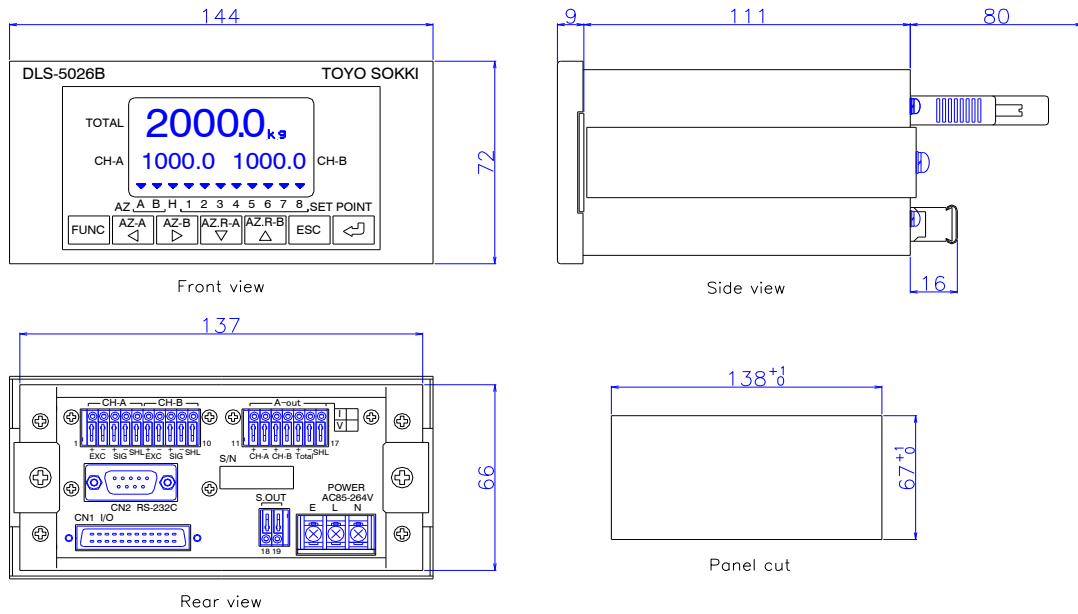

§ 1 4. Function Block Diagram

